



KALORINA K 22 E

TATANO
energie rinnovabili



**CALDAIE A BIOMASSA
SISTEMI SOLARI**

Zona ind.le - Scalo ferroviario
92022 Cammarata (Ag)
Tel. +39 0922 901376
E-mail: tatano@tatano.it
www.tatano.it

BOILER MODEL		K 22 06 E	
Generator type			Smoke tubes
Carrier Fluid			Water
Rated Power		<i>kW</i>	64
Nominal Power		<i>kW</i>	58
Reduced Power		<i>kW</i>	17
Efficiency	<i>min</i>	%	89
	<i>max</i>	%	92
Boiler class according to norm	<i>EN 303-5 : 1999</i>		3

CONSTRUCTION DATA ⁽¹⁾

Dimensions with standard hopper	<i>Width</i>	<i>mm</i>	(A)	1350
	<i>Depth</i>	<i>mm</i>	(B)	1180
	<i>Height</i>	<i>mm</i>	(C)	1276
Dimensions for the opening of the door for cleaning		<i>mm</i>	(L)	460
Loading Door dimensions	<i>Width</i>	<i>mm</i>	(H)	370
	<i>Height</i>	<i>mm</i>	(I)	220
Standard hopper volume		<i>litres</i>		190
Weight		<i>Kg</i>		453
Chimney diameter		<i>Ø mm</i>	(R)	200
Ash tray Volume		<i>litres</i>		/

HYDRAULIC DATA

Max working pressure		<i>Bar</i>		3
Max working temperature		<i>°C</i>		90
Boiler water content		<i>litres</i>		158
Sleeves UNI/DIN EN 10241- ST 37	<i>Delivery</i>	<i>Ø mm</i>	(O)	DN 50 V (2")
	<i>Return</i>	<i>Ø mm</i>	(P)	DN 40 V (2"1/ 2)
	<i>Expansion tank</i>	<i>Ø mm</i>	(Q)	DN 25 V (1")
	<i>Heat sink</i>	<i>Ø mm</i>	(K)	DN 14
Loading drop in the water side 20 k		<i>mbar</i>		9

OPERATING DATA

Draught Pressure		<i>Pa</i>		20±(30%)
Smoke temperature		<i>°C</i>		180±(20%)
Fuel flow setting				Electronic modulating
Ventilation flow setting				Electronic modulating

FUELS

Recommended class			WOOD PELLETT (EN 14961-2)
Fuel with W < 15%			Marc of olives, minced shells and cereal waste (EN 14961-6); Wood (EN 14961-5)
	Wood max		580 mm

REFERENCE FUEL

PELLET⁽²⁾

Consumption with nominal power		kg/h	12,8
Consumption with reduced power		kg/h	3,8
Smoke flow with nominal power		Nm ³ /h	136
Smoke flow with reduced power		Nm ³ /h	40,7

ELECTRICAL DATA⁽³⁾

Control panel			Modulating digital electronic thermoregulator complete with main switch, manual reset thermostat, light indicators
Ignition			Electrical through resistor 250 W, 230 V, 1A
Installed electric power		W	660
Average power input		W	205
Rated Voltage		V	230
Nominal frequency		Hz	50
Nominal current		A	4,00

STANDARD ACCESSORIES

Combustion chamber cleaning system			Through ash tray on wheels
Heat exchanger cleaning system			Trough compressed air jets

ARRANGEMENTS

Burner connection			Gas and/or fluid fuels
Remote assistance			Output connection
Room thermostat			Output connection
Water Pressure switch			Output connection
Antifire valve application			Through threaded sleeves DN 20 (3/4")

OPTIONAL

Remote assistance\Remote control			Hopper position Wifi module
SECURITY SYSTEM			Antifire valve

SECURITY SYSTEM

			Anti-freeze programming
Signaling, control and boiler stop			Through boiler probe and smoke probe
			Manual resetting thermostat
			Boiler block for open hatch
Reporting of operating errors			Fuel level sensor
			Through visual and/or acoustic alarms

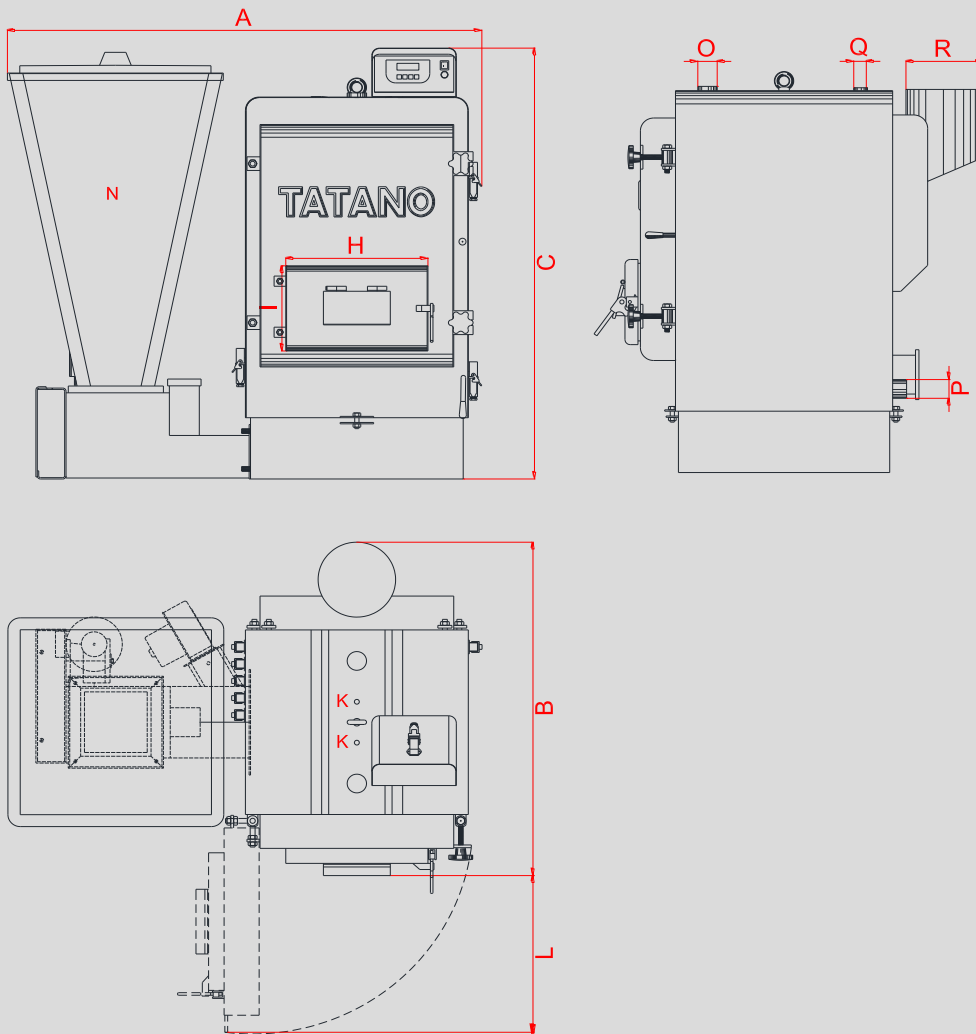

(1) The dimensions may vary depending on the position of the hopper(right-left-rear) or in addition of optional accessories or for constructive choices.

(2) The data concerning consumption may vary according to the characteristics of the fuel used, or for the operating conditions.

(3) Data may vary according to the electrical components installed (motors, fans, etc.). The actual data will be shown on the plate attached to the boiler.

The company reserves the right to change dimensions and features without prior notice, declines all responsibility for errors in transcription or printing.