



## KALORINA Compact series

**TATANO**  
energie rinnovabili



**CALDAIE A BIOMASSA  
SISTEMI SOLARI**

Zona ind.le - Scalo ferroviario  
92022 Cammarata (Ag)  
Tel. +39 0922 901376  
E-mail: tatano@tatano.it  
[www.tatano.it](http://www.tatano.it)

BOILER MODEL	K35 CHIPS		
Generator type			Smoke tubes
Carrier Fluid			Water
Rated Power		<i>kW</i>	37,6
Nominal Power		<i>kW</i>	34
Reduced Power		<i>kW</i>	10
Efficiency	<i>min</i>	%	89
	<i>max</i>	%	92
Boiler class according to norm	<i>EN 303-5 : 1999</i>		3

### COSTRUCTION DATA <sup>(1)</sup>

Dimensions with standard hopper	<i>Width</i>	<i>mm</i>	(A)	1200
	<i>Depth</i>	<i>mm</i>	(B)	820
	<i>Height</i>	<i>mm</i>	(C)	1243
Dimensions for the opening of the door for cleaning		<i>mm</i>	(L)	410
Loading Door dimensions	<i>Width</i>	<i>mm</i>	(H)	350
	<i>Height</i>	<i>mm</i>	(I)	330
Standard hopper volume for CHIPS		<i>liters</i>		340
Weight		<i>Kg</i>		410
Chimney diameter		<i>Ø mm</i>	(R)	150
Ash tray Volume		<i>liters</i>		9

### HYDRAULIC DATA

Max working pressure		<i>Bar</i>		3
HSW production		<i>litres/min</i>		10
Max working temperature		<i>°C</i>		90
Boiler water content		<i>liters</i>		91
Sleeves UNI/DIN EN 10241- ST 37	<i>Delivery</i>	<i>Ø mm</i>	(O)	DN 25 V (1")
	<i>Return</i>	<i>Ø mm</i>	(P)	DN 25 V (1")
	<i>Expansion tank</i>	<i>Ø mm</i>	(Q)	DN 25 V (1")
	<i>HSW copper coil</i>	<i>Ø mm</i>	(K)	DN 14
Loading drop in the water side 20 k		<i>mbar</i>		55

### OPERATING DATA

Draught Pressure		<i>Pa</i>		20±(30%)
Smoke temperature		<i>°C</i>		180±(20%)
Fuel flow setting				Electronic modulating
Ventilation flow setting				Electronic modulating

## FUELS

Recommended class			Wood Chips (EN 14961-4)
Fuel with W < 15%			Wood Pellet (EN 14961-2), Sawdust (EN 14961-3), Olive husks, Minced shells and Cereals waste (EN 14961-6), Wood (EN 14961-5)
	Wood max		500 mm

## REFERENCE FUEL<sup>(2)</sup>

Combustion mode			CHIPS
Consumption with nominal power		kg/h	9,9
Consumption with reduced power		kg/h	3,0
Smoke flow with nominal power		Nm <sup>3</sup> /h	80,0
Smoke flow with reduced power		Nm <sup>3</sup> /h	24,0

## ELECTRICAL DATA<sup>(3)</sup>

Control panel			Modulating digital electronic thermoregulator complete with main switch, manual reset thermostat, light indicators
Ignition			Electrical through resistor 250 W, 230 V, 1A
Installed electric power		W	780
Average power input		W	265
Rated Voltage		V	230
Nominal frequency		Hz	50
Nominal current		A	4,70

## ARRANGEMENTS

Burner connection			Gas and/or fluid fuels
Remote Control-Remote Assistance			Output connection
Room thermostat			Output connection
Water Pressure switch			Output connection

## OPTIONAL

Remote Control-Remote Assistance			Wifi module
----------------------------------	--	--	-------------

## SECURITY SYSTEM

				Anti-freeze programming
<b>Reporting, control and boiler stop</b>				Through boiler probe and smoke probe
				Manual resetting thermostat
				Boiler block for open hatch
				Boiler block for open fuel silos lid
<b>Reporting of operating errors</b>				Fuel level sensor
				Through visual and/or acoustic alarms

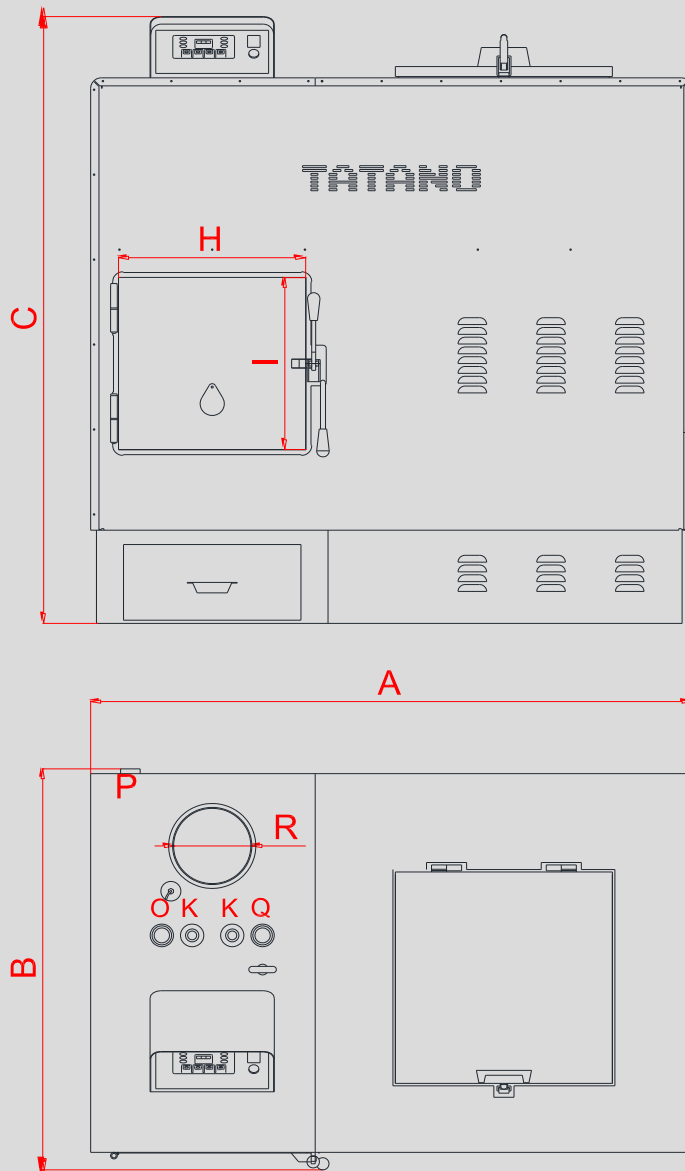

(1) The dimensions can vary according to choices of constructive nature

(2) The data concerning consumption may vary according to the characteristics of the fuel used, or for the operating conditions.

(3) Data may vary according to the electrical components installed (motors, fans, etc.). The actual data will be shown on the plate attached to the boiler.

The company reserves the right to change dimensions and features without prior notice, declines all responsibility for errors in transcription or printing.